

ER II 800



Affordable and Intelligent -
Apt Option for Future Labelling Scales



ER II 800 Label Printing Scale

Features

- Display : 4.3" LCD Color Operating Display easy to read and operate
- Cassette Type : Simple and fast paper changing
- Currency: USD, L.L and many more
- English, Arabic Language for PLUs

Interfaces

- Cash box port
- RS232
- USB 2.0
- LAN
- Inbuilt WiFi

Back Office Management

- Label Design
- Product Management
- Device Management
- Preset PLU Management

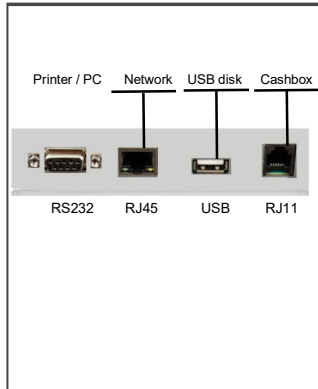
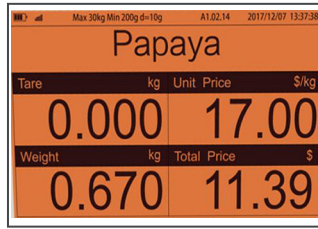

Technical Data

- Operator Display** - 4.3" Color Display
- Customer Display** - 4.3" Color Display
- Print speed** - 100mm/s
- Maximum PLUs** - 10,000
- Power** - 100 - 250VAC
- Maximum printing width** - 56x120mm
- Scale plate size** - 272x380mm
- Operating temperature** - -10°C - 40°C
- Maximum paper width** - 60mm
- Preset Keys** - 80

Model	Capacity Max kg	Readability g
ER II 800 - 6	6	1
ER II 800 - 15	15	2
ER II 800 - 30	30	5

*Specifications are subject to change without notice.

Accessories

- Cash Drawer
- Back Office Software
- Additional Paper Cassette

Members of the Bizerba Group

Bizerba India Private Limited
India Land Global Industrial Park,
Plot No.5, Hinjewadi Phase 1,
Pune - 411 057, Maharashtra, India.
Tel: +91-020-67712700
marketing.india@bizerba.com
www.bizerba.com

Bizerba GmbH & Co. KG
Wilhelm-Kraut-Strabe
6572336 balingen
Germany
Tel. +49 7433 12-0
Fax +49 7433 12-2696
marketing@bizerba.de
www.bizerba.com

Bizerba UK Limited
2-4 Erica Road
Stacey Bushes
Milton Keynes
Buckinghamshire
MK12 6HS, U.K.
Tel. +44 1908 682740
Fax +44 1908 682777
sales@bizerba.co.uk
www.bizerba.com

Bizerba USA Inc.
31 Gordon Road Piscataway
New Jersey 08854 USA
Tel. Office +1 732 565-6000
Tel. Service + 1 732 565-6001
Fax +1 732 819-0429
us.info@bizerba.com
www.bizerbausa.com

Bizerba Canada Inc.
2810 Argenta Road
#9 Mississauga,
Ontario L5N 8L2
Canada
Tel. +1 905 816-0498
Fax +1 905 816-0497
ca.info@bizerba.com
www.bizerba.com

Bizerba South East Asia Pvt.Ltd.
1 Fifth Avenue #02-05 Guthrie
House Singapore 268802 Singapore
Tel. +65 6465-1900
Fax +65 6468-0481
bizerba@bizerba-sea.com
www.bizerba-sea.com