

SC II 100 / SC II 200 ...

SC II 100

Platform scales for serving customers, self-service and price labelling. Checkout area solutions combined with a cash till drawer.



SC II 100 customer view

SC II 200

Platform scales with customer display on stand for serving customers and price labelling.



SC II 100

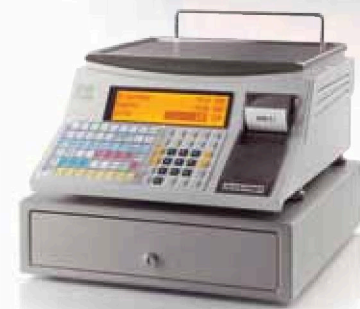

SC II 100
With Niro cash till drawer



SC II 200 customer view



SC II 200

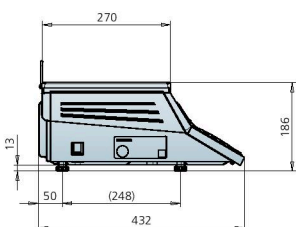

SC II 100

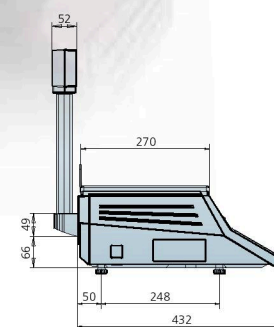
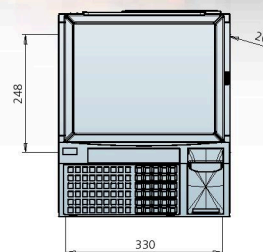
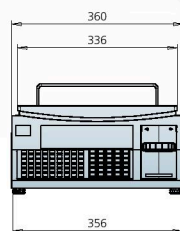

SC II 200

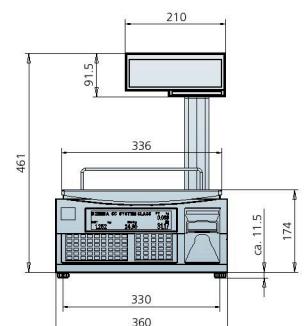

SC II

Weighing range	3/6 kg	6/15 kg	15/30 kg ¹⁾	30 kg ¹⁾
Scale interval	1/2 g	2/5 g	5/10 g	5 g
Minimum load	20 g	40 g	100 g	100 g
Max load	-6 kg	-15 kg	-30 kg	-30 kg
Automatic zeroing function, programmable zeroing key				¹⁾ Option

SC II 100 G with load receptor type 150/350 in (kg)

Weighing range	6/15	15/30	30	30/60	60	120	60/150
Scale interval	2/5 g	5/10 g	5 g	10/20 g	10 g	20 g	20/50 g
Minimum load	40 g	100 g	100 g	200 g	200 g	400 g	400 g

Load receptor type 150/350

- Bell-shaped weighing platform is made of stainless steel
- The main and platform frame are made of milde steel (galvanized) or in stainless steel

Display

- LCD dot matrix display 64 x 240 dot with LED back lighting, colour: orange
- Adjustable contrast and brightness
- Character count for text: approx. 35
- Number of lines for programming: 6
- Weight display: 4 or 5-digit
- Basic price display: 6-digit, Sale price display: 7-digit
- Tare weight display: 4 or 5-digit

Customer screen (option) for SC II 100, 400 and 800

- 7" TFT LCD colour screen with LED backlighting, WVGA resolution (800 x 480 dots)
- Product images
- Cross-selling images
- Full-screen advertising
- Long-term advertising

Keypad

- Membrane or tactile keypad (option), 84 keys incl. 30 function and 54 direct keys for PLU and/or other functions
- Flexible programming
- Integrated programming keypad
- Membrane keypad can be labelled via insert and tactile keypad via frame (option)
- Frame attached to tactile keypad with 24 self-service keys

Self-service keypad (SC II 400 and SC II 500)

- Short-stroke, tactile with membrane
- Number of self-service keys: 48 standard and a further 48 via additional panel with model SC II 500 (option)
- Frame attachable to operator keypad with 24 self-service keys (option)
- Number of self-service keys: max. 72 or 120
- Extra large self-service keys: max. 12 or 24
- Mixed components with different key sizes possible

Fast operator keypad (SC II 400 and SC II 500)

- Short-stroke, tactile with membrane
- Number of QS keys: 96 standard and a further 96 via additional panel with model 500 (option)
- Extra large QS keys: max. 12 or 24
- Mixed components with different key sizes possible

Label printer

- 432 dots
- Resolution: 8 dots/mm
- Print speed: 102 mm/s
- Graphics, logo printing, large/small lettering, various font types and sizes, EAN/UPC barcodes
- Label length max. 300 mm, label width max. 58 mm, print width 52 mm
- Flexible configuration of label size and layout, various pre-defined label sizes and layouts
- Transposable onto adhesive or receipt paper
- Label layout on receipt paper
- Selectable counterfoil

Linerless printer

- Like the label printer
- Receipt and label layout without carrier tape
- Variable label length depending on data quantity

Operating system

- Microsoft Windows® CE

Data storage

- 32 MB on SD card

Programmable data per PLU

- Basic/ unit price, product description max. 500 characters, additional text max. 6000 characters, product images, product group, shelf life, barcode, price override, tare weight, VAT, offer price, offer text, by count (= number of items), fixed weight, price basis kg, 100 g, 500 g, lb, 1/4 lb, graduated price, timed campaigns, 3 price categories

Operating modes

- Operator, self-service and quick service- Cash till functions with pay-in/out function
- Manual or automatic price labelling, with or without addition
- Weight and fixed price labelling
- Pre-selected number for automatic printing

Reports/ evaluations

- Comprehensive flexible configuration of reporting for PLU, product groups, main product groups, VAT, sales staff, department, main department, training
- Frequency of sales for department, product groups and sales staff
- Various assortment criteria
- Price modification journal, electronic log of receipts
- In combination with licensed software: cashier, inventory, wastage weighing, returns, operator time recording

Other service features

- Function menus, weighing programmes loadable via interface, various tare weight options, operational help on display, password protected menu, remote programme update, remote service, language switching of menu

Other service features with use as operator scales

- Receipt cancellation, scrolling function with cancellation, paying in/out, foreign currency conversions, seller log on/off, bonus points, customer card

Licences for software module

- Proof of origin, till function, scanning, electronic cash, operator time recording, inventory, weighing, branch returns

Interfaces

- 1 x Ethernet interface (10/100 Mbit/s) for the scales system with up to 32 devices or to connect to computer, for automatic configuration of the network parameters DHCP and DNS. Data protocol. TCP/IP and UDP, data transfer by XML file
- 2 x serial interfaces RS 232 for connecting a scanner or electronic cash terminal (interface protocol subject to licence)
- 1 x USB port for version with 7" TFT colour screen
- 1 x interface (RJ 12) for controlling cash till drawer
- Wireless LAN (option) IEEE 802.11 b/g/a for floating vendor operating with up to 16 devices or for connecting to a computer
- Various forms of encryption and authentication

Battery operation (option)

- Internal lithium-ion battery pack (not for the SC II 400 model and not in combination with wireless LAN), can be charged via the scales power supply within 3.5 hours
- Operating time approx. 10 hours with LCD dot matrix display
- Operating time approx. 2 hours (UPS) with 7" TFT colour screen (Operating time dependent on ageing and charge state of rechargeable battery)

External battery operation (option)

- 12 V, via a special battery connection cable (not for the SC II 400 model and not in combination with wireless LAN)

Temperature range

- -10 °C to +40 °C

Operating voltage

- (- 15 + 10 %) 230 V or (- 15 + 10 %) 120 V

Power consumption

- at 230 V min. 60 mA / max. 250 mA, at 120 V min. 75 mA / max. 350 mA

Network frequency

- 50 / 60 Hz

Members of the Bizerba Group

Bizerba GmbH & Co. KG
 Wilhelm-Kraut-Straße 65
 72336 Balingen
 Germany
 Tel. +49 7433 12-0
 Fax +49 7433 12-2696
 marketing@bizerba.com
 www.bizerba.com

Bizerba (U.K.) Limited
 Bizerba House
 Eastman Centre
 Eastman Way
 Hemel Hempstead
 Herts HP 2 7 DU
 U.K.
 Tel. +44 1442 24-0751
 Fax +44 1442 2313-28
 sales@bizerba.co.uk

Bizerba USA Inc.
 31 Gordon Road
 Piscataway
 New Jersey 08854
 USA
 Tel. Office +1 732 565-6000
 Tel. Service +1 732 565-6001
 Fax +1 732 819-0429
 us.info@bizerba.com
 www.bizerbausa.com

Bizerba Canada Inc.
 2810 Argentinia Road #9
 Mississauga,
 Ontario L5N 8L2
 Canada
 Tel. +1 905 816-0498
 Fax +1 905 816-0497
 ca.info@bizerba.com
 www.bizerba.ca

Bizerba South East Asia
 Pte. Ltd.
 1 Fifth Avenue #02-05
 Guthrie House
 Singapore 268802
 Singapore
 Tel. +65 6465-1900
 Fax +65 6468-0481
 bizerba@bizerba-sea.com
 www.bizerba-sea.com